



Work Supports

off-position extended – contact by spring force, single acting, max. operating pressure 500 bar



The plunger internal thread should always be plugged by a plastic cap or a screw-in extension to protect the element against penetration of liquids.

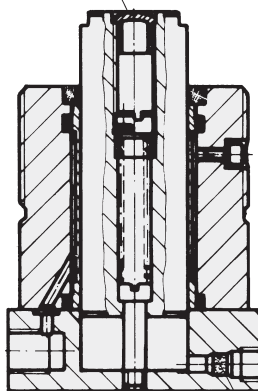

Sintered metal air filter
Connection for ventilation hose ND 6
by hose fitting **3300-921**
(shown offset by 90°)

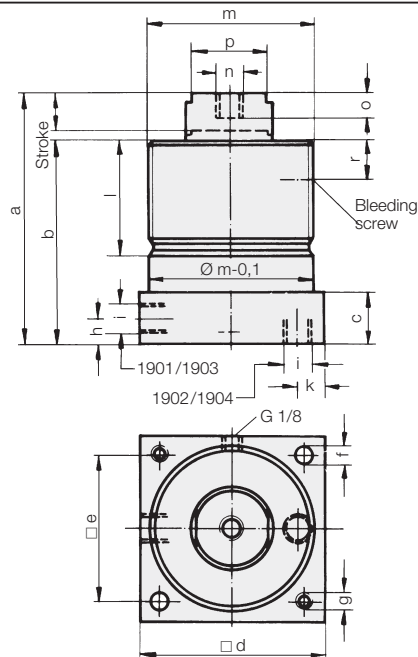

Application

Hydraulic work supports are used to provide a self-adjusting rest for the workpiece during the machining operations. They compensate the workpiece surface irregularities, also deflection and vibration under machining loads.

Description

The spring-loaded plunger positions itself against the workpiece with an adjustable light spring force. Hydraulic locking is made together with hydraulic clamping of the workpiece, or independently. The support plunger is provided with female thread to enable the use of threaded pieces for height adjustment. Oil supply can alternatively be effected from the side or from below.

The internal part of the work support is protected against dust and swarf by a sintered metal air filter.

Recommended minimum pressure 100 bar, spring force adjustable from 10 to 90 N, depending on stroke.

Important notes!

If there is any danger of fluids being sucked into the filter, a vent hose has to be connected. Spring force should not be used to lift workpieces.

Contact bolts and extensions with large weight can influence the functions of this component.

Work supports are not suitable to compensate side loads. Operating conditions, tolerances and other data see data sheet A 0.100.

It is absolutely necessary to follow the instructions for venting of the spring area on data sheet A 0.110.

Connections		on side	at the bottom	on side	at the bottom
Plunger Ø	[mm]	32	32	40	40
Plunger stroke	[mm]	16	16	18	18
a	[mm]	112	112	118	118
b	[mm]	90	90	96	96
c	[mm]	24	24	24	24
d	[mm]	75	75	85	85
e	[mm]	57	57	68	68
f	[mm]	7	7	9	9
g	[mm]	M 6	M 6	M 8	M 8
h	[mm]	12	–	12	–
i		G 1/4	G 1/4	G 1/4	G 1/4
k	[mm]	–	12	–	12
l	[mm]	40	40	54	54
m	[mm]	M 68 x 2	M 68 x 2	M 78 x 2	M 78 x 2
n	[mm]	M 12	M 12	M 12	M 12
o	[mm]	12	12	12	12
p	[mm]	27	27	36	36
r	[mm]	20	20	18	18
x	[mm]	Ø 80	Ø 80	Ø 90	Ø 90
Weight	[kg]	2,7	2,7	3,8	3,8
Part-no.		1901-001	1902-001	1903-001	1904-001
Accessory: Capstan nut		3522-008	3522-008	3522-007	3522-007

Accessory

Capstan nut

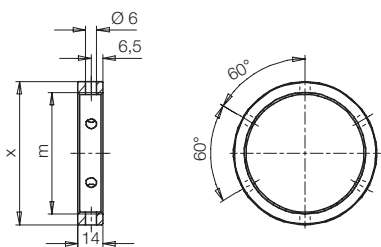

Admissible load F as function of the operating pressure p

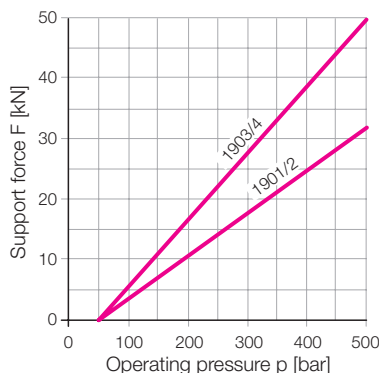

Max. elastic deformations s as a function of support force F

