



Hollow Piston Cylinders

single acting, hydraulic clamping and spring unclamping

max. clamping force of 30 kN up to 104 kN, max. operating pressure 400 bar



Advantages

- Optimum adaptation to the clamping surface by spherical disk
- T-bolt, secured against loosening
- Ideal force transmission
- Convenient and compact design with gripping surface
- Large clamping stroke
- No interfering edges when inserting the dies
- Easy to retrofit
- Piston hardened and ground
- Easy installation
- Fully resilient stroke limitation

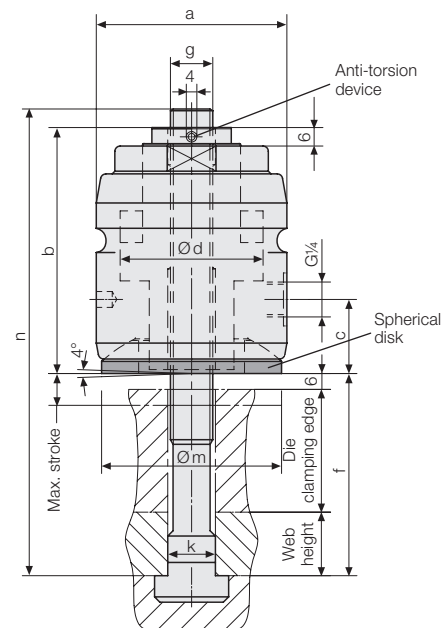

dimension "f" = die clamping edge + web height + ½ stroke

Application

These hollow-piston cylinders are used for clamping and locking on machines and plants, on press bed and ram.

Due to the manageable and compact design, hollow-piston cylinders are especially suitable where space is limited.

The use is possible at ambient temperatures up to a maximum of 120 °C.

Description

The element is manually placed on the clamping edge of the die.

Clamping by the application of hydraulic pressure to the piston and unclamping by spring force. By means of the T-bolt the die is clamped against the clamping surface of the press ram or bed.

Hollow piston cylinder with T-bolt

adjusted and secured (please specify dimension "f" when ordering)

For T-slot	[mm]	18	22	28	36
Clamping force at 400 bar	[kN]	60	60	104*	104*
Spring return force, min.	[N]	320	320	570	570
Piston Ø d	[mm]	54	54	70	70
Stroke	[mm]	12	12	12	12
Total oil volume	[cm³]	18	18	32	32
a	[mm]	72	72	90	90
b	[mm]	93	93	105	105
c	[mm]	30	30	27	27
g	[mm]	M 16	M 20	M 24	M 30
k	[mm]	18	22	28	36
m	[mm]	68	68	78	78
Weight	[kg]	2.39	2.67	4.77	5.29
Part no.		821341802	821342202	821352802	821353602

Max. operating pressure 400 bar, * 160 kN on request

Hollow piston cylinder without T-bolt

Weight	[kg]	2.1	2.09	3.67	3.49
Part no.		821340102	821341102	821350102	821351102

T-bolt, separate

For T-slot	[mm]	18	22	28	36
n	[mm]	160	200	250	250
Property class		12.9	12.9	12.9	8.8
Weight	[kg]	0.29	0.58	1.10	1.8
Part no.		5700022	5700023	5700024	5700048

Example of ordering

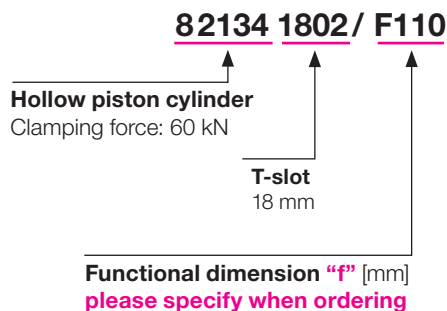

Important note!

If hollow piston cylinder and T-bolt are supplied separately, adjust them to suit dimension "f" and secure them.

Accessories

Parking station without position monitoring

accommodates the hollow piston cylinder during die change.

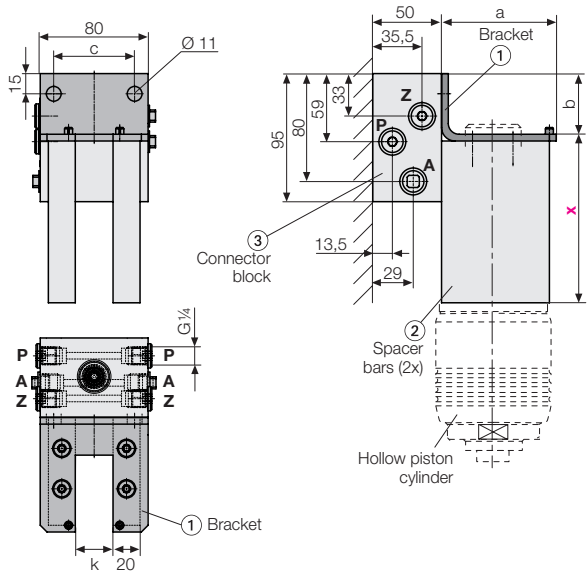

Distance dimension "x"
= Dimension "a" - 1/2 stroke
please specify when ordering

Hydraulic circuit diagram

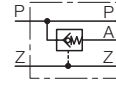

Application with integral check valve

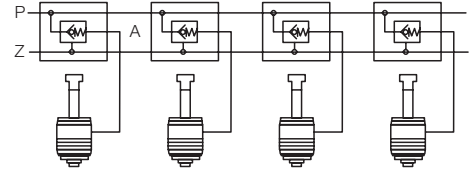

Part numbers

for hollow piston cylinder type	2132	2133	2134	2134	2135	2135
T-slot width k	14	16	18	22	28	36
a [mm]	60	60	72	72	85	90
b [mm]	40	40	45	45	45	45
c [mm]	36	36	60	60	60	60
Bracket ①	Part no. 2753140	2753160	2753180	2753220	2753280	2753360
Bracket ① with mounted spacer bars ②	Part no. 827531430	827531630	827531830	827532230	827532830	827533630
Bracket ① with spacer bars ② and connector block ③	Part no. 827531450	827531650	827531850	827532250	827532850	827533650
Connector block ③ (separate) with integral check valve	Part no. 827534012	827534012	827534002	827534002	827534002	827534002

Special designs on request

Parking station with position monitoring

An inductive proximity switch indicates when a hollow piston cylinder is mounted to the parking station.

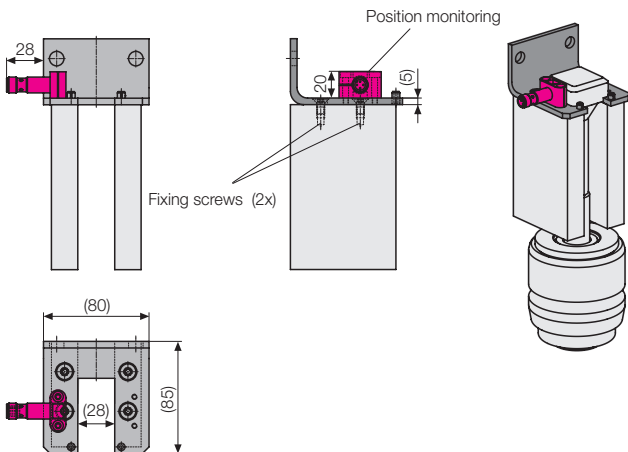

Position monitoring

Control options

- The correct number of clamping cylinders and thus sufficient clamping force is available
- Operator protection: no clamping cylinder will be forgotten
- Control of a selective selection per tool size is possible

Please contact us!

Other accessories

- **Hydraulic power units**
see product group 7
- **Hydraulic accessories**
see product group 11
- **Angular rotary coupling**
Part no. 9208176

Hollow piston cylinder “L” design without spherical disk

Hollow piston cylinder “L” design without spherical disk

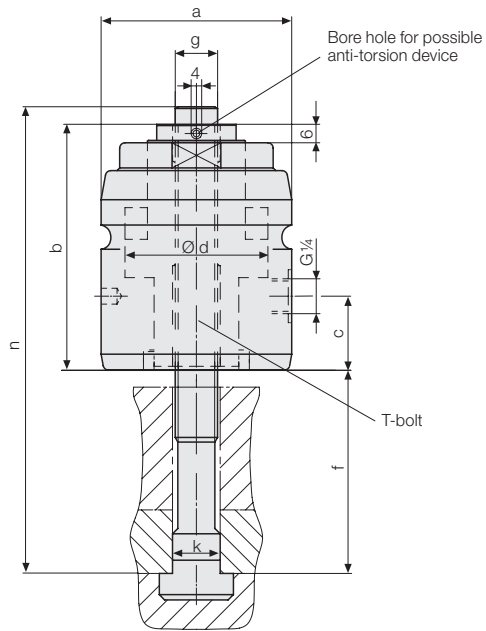

Hollow piston cylinder “L” design without spherical disk with T-bolt

- with adjusted and secured T-bolt (specify dimension ‘f’ when ordering)
- without spherical disk

For T-slot	[mm]	14	16	18	22	22	28	36
Clamping force at 400 bar	[kN]	30	40	60	60	60	104	104
Spring return force, min.	[N]	255	360	320	400	320	570	570
Piston Ø d	[mm]	35	42	54	54	54	70	70
Stroke	[mm]	8	8	12	6	12	12	12
Total oil volume	[cm ³]	6	8	18	9	18	32	32
a	[mm]	50	58	72	72	72	90	90
b	[mm]	64.5	66.5	92.5	67	92.5	104	104
c	[mm]	13	14	29	12	29	26	26
g	[mm]	M12	M14	M16	M20	M20	M24	M30
k		14	16	18	22	22	28	36
m		G 1/8	G 1/8	G 1/4	G 1/4	G 1/4	G 1/4	G 1/4
Weight	[kg]	1.0	1.2	2.5	2.0	2.8	4.8	5.4
Part no.		821321432	821331632	821341832	821342222	821342232	821352832	821353632

Max. operating pressure 400 bar

Hollow piston cylinder “L” design without spherical disk without T-bolt

- without spherical disk

For T-slot	[mm]	14	16	18	22	22	28	36
Weight	[kg]	0.75	1.0	2.2	1.7	2.2	3.8	3.6
Part no.		821320132	821330132	821340132	821341122	821341132	821350132	821351132

Important note!

If hollow piston cylinder and T-bolt are supplied separately, adjust them to suit dimension “f” and secure them.

Accessories

T-bolt, separate

For T-slot	[mm]	14	16	18	22	22	28	36
n	[mm]	125	125	160	200	200	250	250
Property class		12.9	8.8	12.9	12.9	12.9	12.9	8.8
Weight	[kg]	0.16	0.19	0.29	0.58	0.58	1.1	1.8
Part no.		5700143	5700144	5700022	5700023	5700023	5700024	5700048

Variant with a total stroke of 20 mm

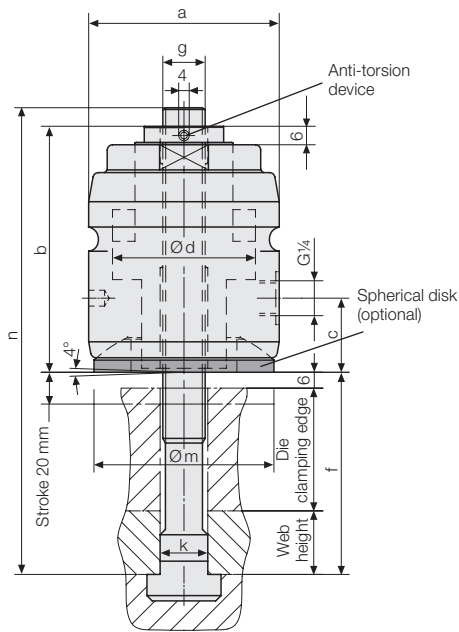

Optimum adaptation to varying heights of the clamping edges of dies by an increased total stroke of 20 mm (higher total stroke on request).

Technical design, clamping forces and dimensions correspond to the standard design. Due to the increased total stroke, dimension "b" is greater than indicated on page 1.

Total stroke 20 mm:

Dimension "b" with a clamping force of 60 kN:
120 mm

Dimension "b" with a clamping force of 104 kN:
132 mm

Variant with variable clamping dimension

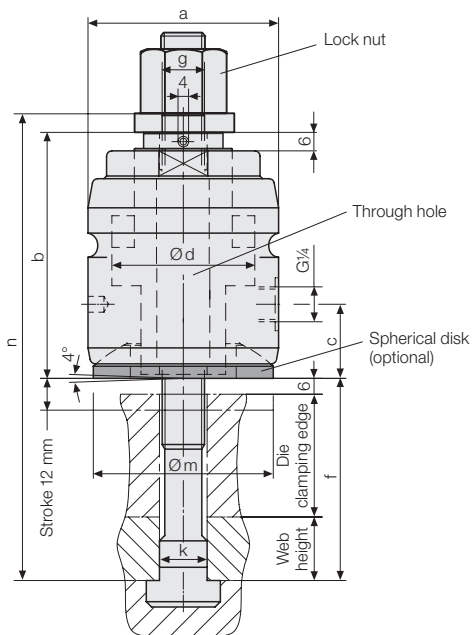

Freely adjustable and flexible adaptation to suit varying heights of clamping edges of the dies by quick and easy adjustment of the tie rod by means of a lock nut.

The tie rod is inserted through the hollow piston cylinder and adjusted to the correct dimension by means of the lock nut.

In this design, the cylinder has a through hole instead of a thread.

Technical design, clamping forces and dimensions correspond to the standard design.

Important notes

Increased risk of injury in the case of an incorrect adjustment of the variants with higher total stroke or variable clamping dimension.

The clamping stroke must be less than 6 mm.