

Hollow piston cylinder, single-acting

• spring clamping • hydraulic unclamping



ROEMHELD

HILMA ■ STARK

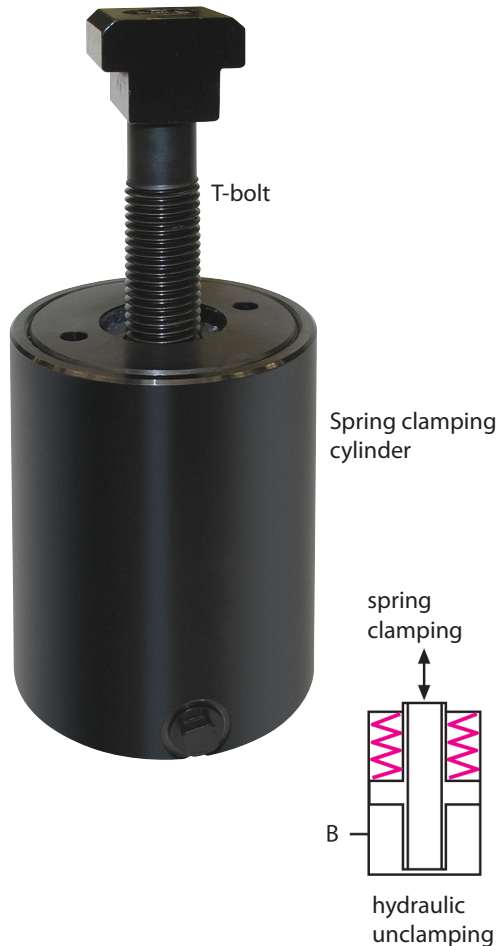

Applications:

- un-pressurized long-term clamping of dies or fixtures on press beds and rams
- when the space available is limited

Function:

Manual positioning of the cylinder on the die clamping edge.

Unclamping is carried out by applying hydraulic pressure to the piston, clamping takes place by spring power.

By means of the T-bolt the die is clamped against the clamping surface of the press ram or bed.

Special features:

- ◇ hydraulic supply is only required for unclamping, i.e. for a short time
- ◇ ideal power transmission
- ◇ convenient and compact design with gripping surface
- ◇ no colliding edges, smooth die positioning
- ◇ suitable for retrofit
- ◇ easy fastening

For suitable power units
please refer to product group 7

For accessories
please refer to product group 11

Recommended accessory:
Angular rotary coupling
part no. HCR-9208-043



Spring clamping cylinder, complete with adjusted and pinned T-bolt, Dimension 'f' to be quoted in the order

For T-slot (mm)	22	28
Clamping force (kN)	50	50
Unclamping pressure (bar)	175	175
Unclamping stroke (mm)	2,5	2,5
Oil consumption/1 mm of stroke (cm ³)	5	5
a (mm)	96	96
b (mm)	125	125
c (mm)	10	10
k (mm)	22	28
Weight (kg)	6,8	7,0
Part no.	HCR-8.1403.2200	HCR-8.1403.2800

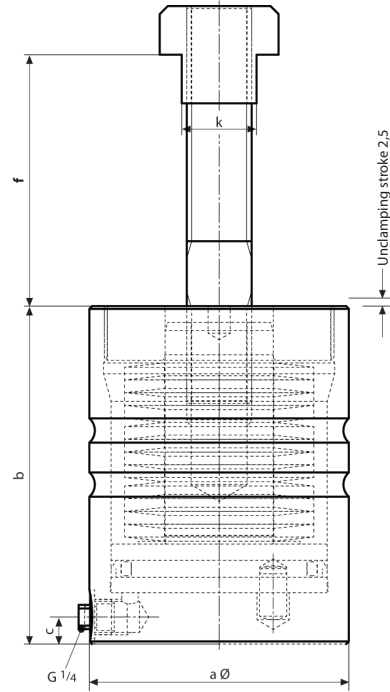
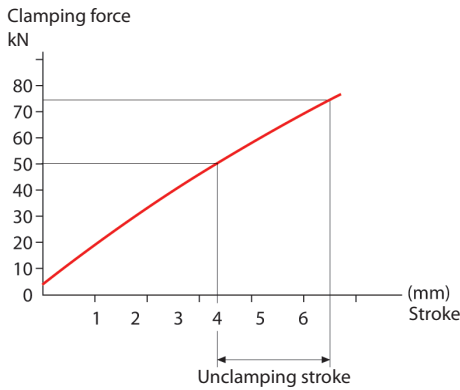

Dimension 'f' =
die clamping edge
+ web height + unclamping stroke

Parking station during die change

Holder with spacer ledges fastened (without a connector block) Part no.	HCR-8.2753.2230	HCR-8.2753.2830
Width of T-slot k (mm)	22	28
a (mm)	72	85
Separate holder Part no.	HCR-2753-220	HCR-2753-280

Special versions are available on request

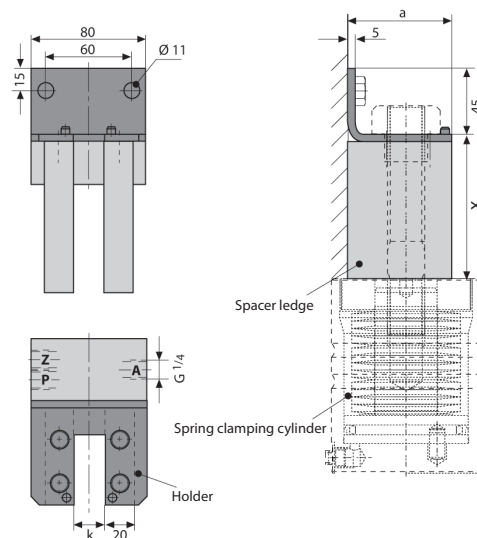

Distance 'x':
x = dimension 'f' - 4 mm
(to be quoted in the order)